

Langlebig

Robust

Wartungsfreundlich

**HOCHDRUCKREINIGER
HIGH PRESSURE CLEANER**

FRANK®



frank-hdr.de

MADE IN GERMANY

**Wandmodul mit
Ölbrenner**
*Wall Module with oil
burner*

**FOM 918 TCC
FOM 1024 TCC
FOM 1415 TCC**



Vor Inbetriebnahme die Betriebsanleitung und Sicherheitshinweise lesen und beachten!



Read the instruction sheet and the safety instructions before putting into operation and observe them!

BETRIEBSANLEITUNG / OPERATING INSTRUCTIONS



Unfallverhütung

Hochdruckstrahl nicht auf Personen, stromführende elektrische Teile und die Maschine selbst richten

Operating safety

Do not direct high pressure jet at persons, electrical components or the machine itself



Table of Content

	Page
1. Application	6
2. Technical data	6
3. Description	7
3.1 Construction.....	7
3.2 Function	8-10
3.3 Oil atomizing burner.....	11-13
4. Installation	13
4.1 Location	13-14
4.2 Assembly dimensions	14
4.3 Connecting the machine	15-16
5. Cleaning and preserving agents	17
5.1 Brennstoff.....	17
5.2 Reinigungs-/Pflegemittel	17
6. Operating instructions	18
6.1 Nozzles and recoil	18
6.2 Operating pressures and spray flow rates	19
6.3 Operating temperatures	19
6.4 Operating the safety spray lance	19
6.5 Spraying with cleaning agents/Preserving agents	20
6.6 Starting the machine.....	21
6.7 Operation of the safety spray lance.....	21
7. Trouble, causes and troubleshooting	22
8. Operating	22
8.1 Preparations for commissioning	22
8.2 Commissioning	22-23
8.3 Battery Change.....	23
8.4 Operating the safety spray lance.....	24

9.	Decommissioning	24
10.	Recommissioning.....	24
11.	Maintenance	25
11.1	High pressure pump	25
11.2	Deliming	25
11.3	Cleaning the heating coil.....	26
12.	Trouble, causes and troubleshooting	27-28
13.	Checking	29
14.	Prevention of accidents	30
15.	Safety instructions.....	30
	Appendix, instructions for heating coil cleaning	31

The ones with the safety indicators  „Warning of a danger point“

marked sections are safety instructions, which must be particularly observed

Versions

Frank - Hot water - High pressure cleaner with electronic safety remote control Telecontrol

Version

On - Off - Control of the machine by operating the spray gun.

Version TCC

On - Off - Control of the machine and program selection by operating the spray gun.

Operating conditions

For safety reasons, only one high-pressure cleaner of the TCA or TCC version may work in one workplace operated or be set up. Also two or more high-pressure cleaner of the different versions of TCA and TCC are not allowed to be operated or set up in a workplace.

The safety distance between high-pressure cleaners of TCA and / or TCC, which are assigned to different workplaces must be at least 50m. This minimum distance also applies to the high-pressure hose assemblies and spraying equipment.

If workplaces with a smaller distance are necessary, machines of the versions TCA or TCC with machines of the variants TCA 2 or TCC 2 respectively TCA 3 or TCC 3 must be combined.

Examples: 2 workplaces with a lower distance than 50m,
TCA combined with TCA 2, or
TCA combined with TCC 2, or
TCC combined with TCC 2.

A maximum of 3 workplaces less than 50m apart,
TCA combined with TCA 2 and TCA 3, or
TCA combined with TCA 2 and TCC 3, or
TCA combined with TCC 2 and TCC 3, or
TCC combined with TCC2 and TCC 3.

1. Application

The wall-mounted FRANK hot water high pressure cleaner module is used for the cleaning, degreasing, phosphatising, preservind and disinfection of vehicles, machines, machine components, containers, etc.

2. Technical data

Machine type	FOM 918 TCC	FOM 1024 TCC	FOM 1415 TCC
High-pressure stage HD			
Maximum flow rate	14,5 l/min	17,0 l/min	23,0 l/min
Maximum working pressure	180 bar	240 bar	150 bar
Admissible working temperature	80 °C	90 °C	70 °C
Steam stage D			
Maximum flow rate	7,5 l/min	9,0 l/min	10,0 l/min
Maximum working pressure	30 bar	30 bar	30 bar
Working temperature	140 °C	140 °C	140 °C
Supply voltage/frequency	400 V 3 N AC 50 Hz	400 V 3 N AC 50 Hz	400 V 3 N AC 50 Hz
Nominal power consumption	5,3 kW, 11 A	7,5 kW, 15 A	7,5 kW, 15 A
Heat capacity	65 kW	80 kW	80 kW
	(56000 kcal/h)	(68800 kcal/h)	(68800 kcal/h)
Fuel consumption	5,5 kg/h	6,7 kg/h	6,7 kg/h
Sound level	max. 80,5 dB (A) *	max. 80,5 dB (A) *	max. 80,5 dB (A) *
Dimensions			
Module			
Length	1000 mm	1000 mm	1000 mm
Width	825 mm	825 mm	825 mm
Height	580 mm	580 mm	580 mm
Master control cabinet	380x380x210 mm	380x380x210 mm	380x380x210 mm
Weight			
Without packing	215 kg	225 kg	225 kg
With packing	285 kg	295 kg	295 kg

* measured outside, in a distance of 1m from the machine surface and 1,6 m above ground.

3. Description

3.1 Construction

The FRANK hot water wall module is a stationary, oil-heated machine. The machine consists of a base plate with wall brackets, water heater with oil atomizing burner, high pressure pump with electric motor, water inlet tank and a separate main control cabinet.

On the pump high-pressure side is the machine with a glycine-damped pressure gauge, Overflow safety valve, flow switch, safety valve, pressure switch.

The structure and dimensions are shown in the following drawing.

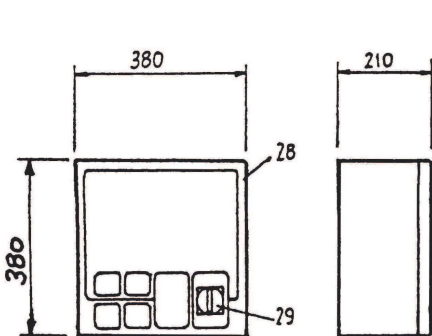
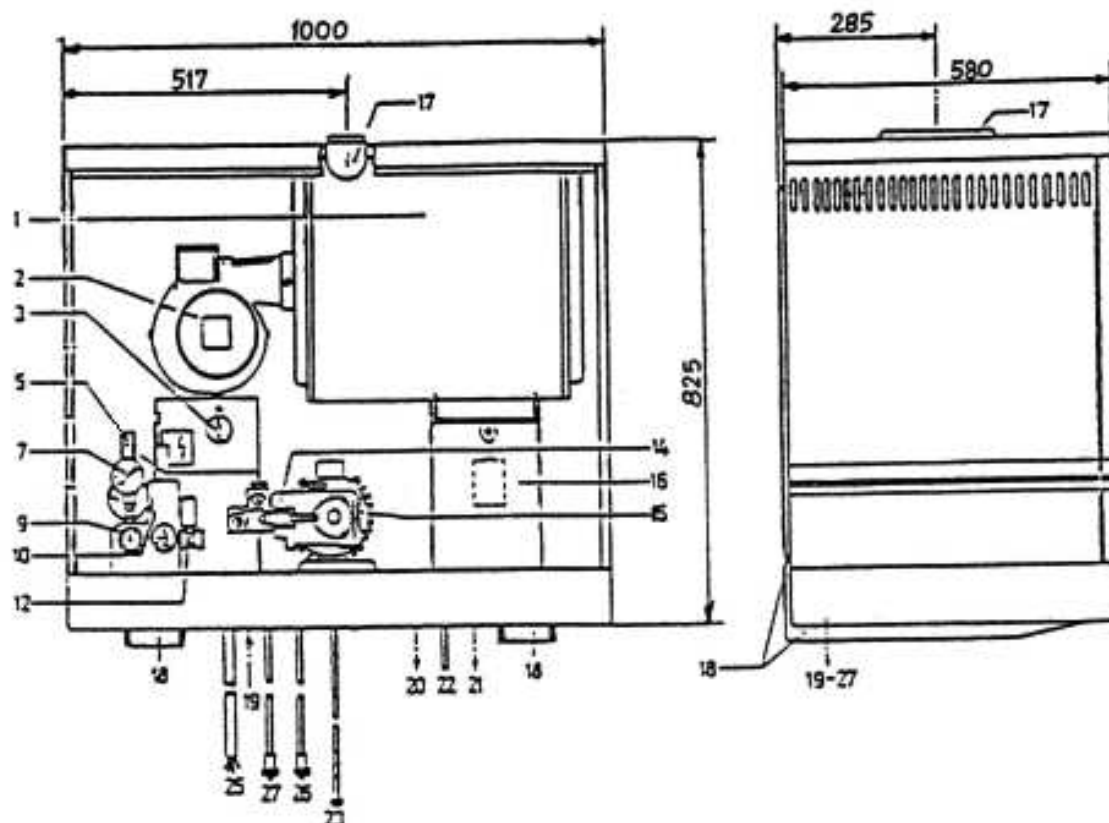

- 1 Water heater
- 2 Atomizing oil burners
- 3 Control thermostat
- 5 Flow Switch
- 7 Pressure gauge
- 9 Overcurrent safety valve
- 10 Dosing valve additive A
- 12 Solenoid valve additive
- 14 High pressure pump
- 15 Electric motor
- 16 Water inlet tank with float valve
- 17 Flue outlet
- 18 Wall bracket
- 19 Connection overflow
- 20 High pressure connection
- 21 Connection overflow
- 22 Condensate drain hose
- 23 Suction hose, additive A
- 25 Electric cable to the main control cabinet
- 26 Hose line heating oil outlet
- 27 Hose line heating oil return
- 28 Main control cabinet
- 29 Main- and hazard switch

3.2 Function

3.2.1 Functional diagram

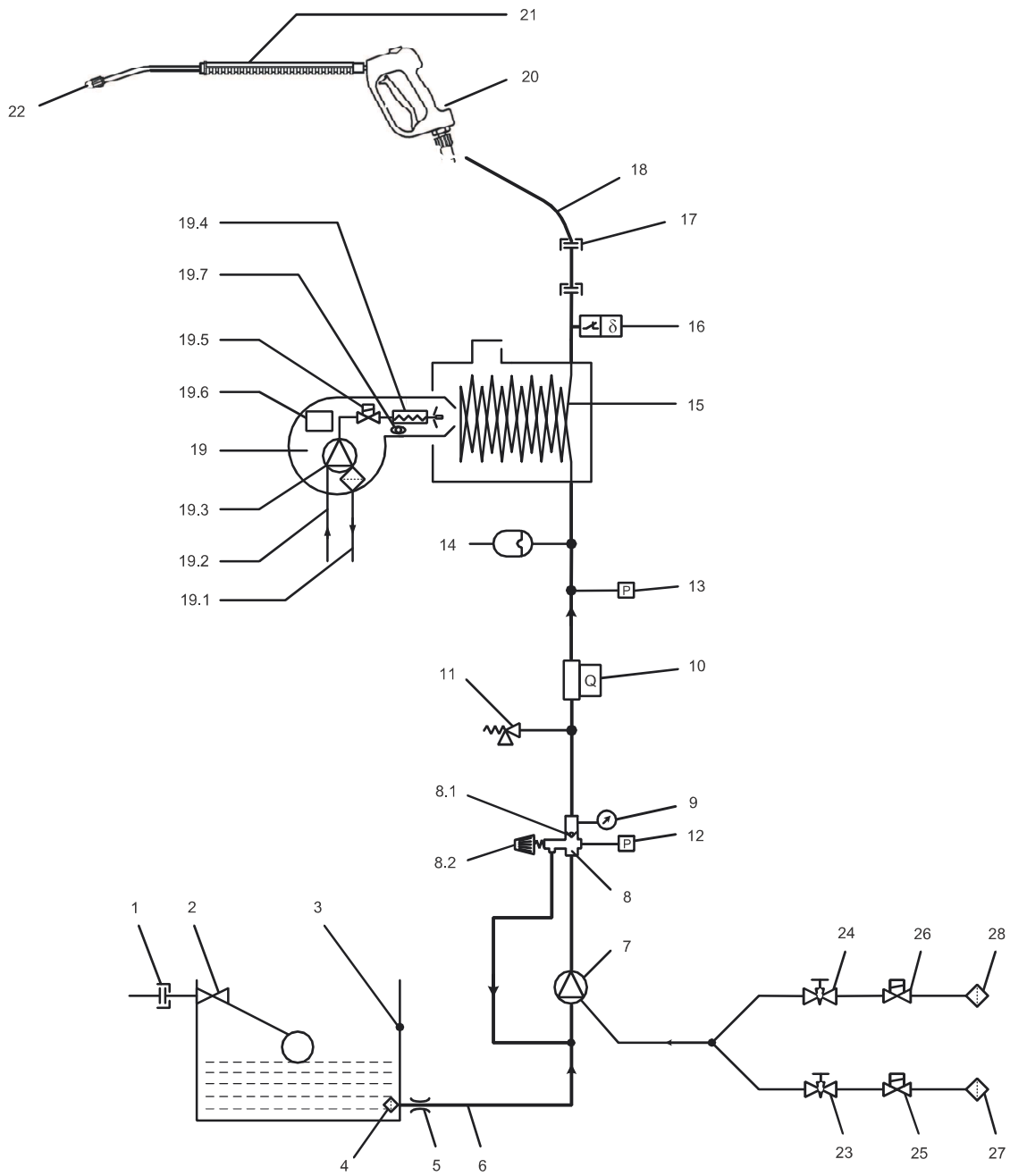

1	Connection – water inlet	17	High-pressure connection
2	Float valve	18	High-pressure hose
3	Water inlet tank	19	Oil atomizing burner
4	Water suction filter	19.1	Fuel oil suction
5	Screen (only FOM 918)	19.2	Fuel oil return
6	Water suction hose	19.3	Fuel oil pump
7	High-pressure pump Overflow-safety valve	19.4	Fuel oilpreheater
8.1	Non-return valve	19.5	Fuel oil solenoid valve
8.2	Turning handle pressure/volume control	19.6	Oil firing contoller
9	Pressure gauge	19.7	Photo cell
10	Flow switch	20	Mechanic spray gun
11	Safety valve	21	Spray lance
12	Pressure switch STOP	22	Nozzle
13	Pressure switch START	23	Dosing valve – detergent A
14	Pressure accumulator	24	Dosing valve – detergent B
15	Heating coil	25	Solenoid valve – detergent A
16	Regulating thermostat	26	Solenoid valve – detergent B
		27	Suction hose – detergent A
		28	Suction hose – detergent B

3.2.2 Water and cleaning / care system

The water flowing in from the mains flows through the float valve into the water inlet tank. The water is then conveyed by the high-pressure pump through the water heater and fed to the spray device under pressure. The nozzle of the sprayer generates a high pressure flat jet. Cleaning / care products can be added via a metering valve and solenoid valve.

3.2.3 Spraying device, spray lance with electronic spray gun

The spray gun enables the machine to be operated only when the safety switch lever is actuated. The machine is switched on by operating the lever. The machine is switched off safely by releasing the lever. The TCC version enables the program to be selected on the spray gun. By pressing the program selection rotary switch, the programs "COLD", "HOT" and "HOT WITH ADDITIVES" can be selected.



The spray gun is a safety device. Repairs may only be carried out by experts. If replacement is required, only components approved by the manufacturer are to be used.



The spray gun is a safety device. Repair works are to be carried out by experts only

3.2.4 Overflow safety valve

The overflow safety valve with integrated electric pressure switch protects the machine against excessive pressure and is designed in such a manner that it cannot be set above the maximum admissible operating pressure. The check nut of the handwheel is sealed with lacquer.



Replacement, repair works, and settings are to be carried out by experts only.

3.2.5 Pressure/Flow regulation

The only standard and permitted operating modes are operating stage D (steam stage) and the operating stage HD (hot water high-pressure stage). In order to change the operating stage a changing-over is necessary, which may be carried out only when the machine is switched off and no pressure is present in the system.

3.2.6 Flow monitor switch

The flow monitor switch operates by using a permanent magnetic piston and solenoid switch. When the spray gun is closed and the water flow to the heating coil is insufficient, the flow monitor switch deactivates the oil burner. This prevents an excessive rise in the temperature of the heating coil, the high-pressure tube and the spraying device.



The flow monitor switch is a safety device. Repair works may be carried out by experts only.

3.2.7 Thermostat

The desired working temperature can be set by actuating the knob on the thermostat.

3.2.8 Control cabinet

All electrical components are centrally installed in the control cabinet. A main and emergency switch is installed in the front door and can be operated from outside the cabinet.



Maintenance and repair work may only be carried out by experts switched off and secured against being switched on again.

3.2.9 Control system fusing

The control fuses of the control transformer in the control cabinet protect the electrical components of the control circuit in the event of faults.

3.2.10 Motor protection

The motor is protected against overloading by an overload release device. In the event of overloading the release device switches off the motor and restarts it again automatically after it has cooled down. If the motor is repeatedly switched off by the release device, the cause of the fault is to be eliminated.

3.3 Oil atomizing burner

Der Ölzerstäubungsbrenner und der zugehörige Wasserehitzer bilden eine Baueinheit.

Type of burner	Water heater Nominal heat load			Fuel oil	Type of machine
	Type	kcal/h	kW		
LB 03	3,2	56 000	65,0	EL DIN 51603	FOM 918
LB 03 - H	3,2	68 800	80,0	EL DIN 51603	FOM 1024 FOM 1415



Adjustment, maintenance and repair works may only be carried out by experts.

3.3.1 Adjustment

The adjustment of the oil atomizing burner has to be done according to the machine checklist and has to be recorded.

ATTENTION!

Only fuel oil as per DIN 51603 should be used. Other types of fuel oil could lead to disturbances of the burner and to inadmissible emission rates.

When adjusting the burner the exhaust rates have to be set to their maximum admissible limit value with a suitable measuring instrument.

Guarantee claims can only be accepted on presentation of a completely filled in initial operation form.

3.3.2 Oil firing controller



The oil firing controller is a safety device. Opening and contacting are inadmissible.

Function

When choosing the programme „HOT“, independent of the oil firing device, the burner fan, fuel oil pump, ignition and oil pre-heater are switched on. Simultaneously the period of a time element with switch-on delay time

After a period of approx. 4 seconds the oil firing controller is switched on, in case the regulating thermostat requires temperature. The oil firing controller opens immediately the fuel solenoid valve and the atomized fuel oil is ignited by the ignition spark already existing. A flame is built, which is controlled by a photo cell.

In case of a disturbance in the form of a flame interruption or a non effected ignition, the fuel oil solenoid valve is closed after a period of 10 seconds.

The disturbance is signalled by an illuminated push button of the oil firing controller. The disturbance must be acknowledged by actuating the illuminated push button in order to restart the programme run of the oil firing controller.

3.3.3 Flame control

The flame control is effected by means of a photo cell. The type is adapted to the oil firing controller.

3.3.4 Ignition electrodes

For a perfect functioning of the ignition, the correct distance between the electrodes and the distance of the electrodes to the nozzles is very important. By careful bending of the electrodes, the correct distances can be attained. The distance can be taken from the special dimension drawing.

3.3.5 Burner motor

The motor is screwed up with the burner housing. For repair works, the wires in the socket of the oil firing controller have to be removed. After loosening the fixing bolts and the fuel oil pipes, the motor together with the fuel pump and fan wheel can be removed. The fan wheel can be removed from the motor shaft by loosening the thread bar, the fuel pump can be removed from the motor housing by loosening the fixing bolts.

3.3.6 Fuel pump with filter

The fuel pump is mounted on the motor. The correct working pressure of the pump is adjusted by means of a test manometer by resetting the oil regulation screw.

3.3.7 Fuel solenoid valve

The fuel solenoid valve is part of the fuel pump. It carries out important functions of the control and safety cut-out of the oil atomizing burner and consists of mechanical and electrical components.



The solenoid valve is a safety device. Repair works and exchange may be carried out by experts only.

3.3.8 Burner nozzle

Contaminated fuel oil can block up the nozzle, can cause burning disturbances and inadmissible emission values so that the nozzle has to be cleaned by means of a nozzle filter or must be exchanged, In case exchange of a nozzle is necessary, only the type in regulation to this machine may be used.

3.3.9 Fuel preheater

The fuel preheater is part of the blast connection. In case of a defective fuel preheater detach wire in the socket of the oil firing controller and exchange preheater.

3.3.10 Ignition transformer

The ignition transformer is attached to the burner housing.

For dismantling:

Detach wire in the socket of the oil firing controller. Remove ignition cable from the ignition electrodes and screw off ignition transformer.

4. Installation

4.1 Location



The machine must not be installed and operated in fire and explosion hazard areas.

Frost protection

The machine, the long-distance pipings and the washing bays have to be installed in such a manner to protect them from frost.

The machine is designed for stationary installation on a solid wall.



The satisfactory solidity of the wall must be checked and approved by an expert on site. If there is no sufficient solidity of the wall for wall installation, the machine is to be mounted on a scaffolding. Machines with oil atomizing burners must be installed in rooms only which comply with the local firing regulations resp. to the local heating room regulations.

The room must have appropriate dimensions and must be equipped in such a manner that exhaust gas duct, aeration and deaeration are guaranteed and a proper installation is possible.

The machine and the control cabinet must be installed in such a manner that the operation and all maintenance works can be carried out properly. It is very important that the rear heating coil cover is easily accessible and demountable

Take care of:

- Volume
- Height
- Minimum air let cross section 410 cm²

Examples according to the Firing regulation for the land of the Federal Republic of Germany Hessen.

- Volume minimum 8 m³
- Clear height minimum 2 m, for wall modules the clear height must be minimum 2,5 m
- Minimum air inlet cross section 410 cm²

Take care of the special requirements for fuel oil burners.

All criteria must be agreed with the local senior chimney sweeper.

4.2 Assembly dimensions

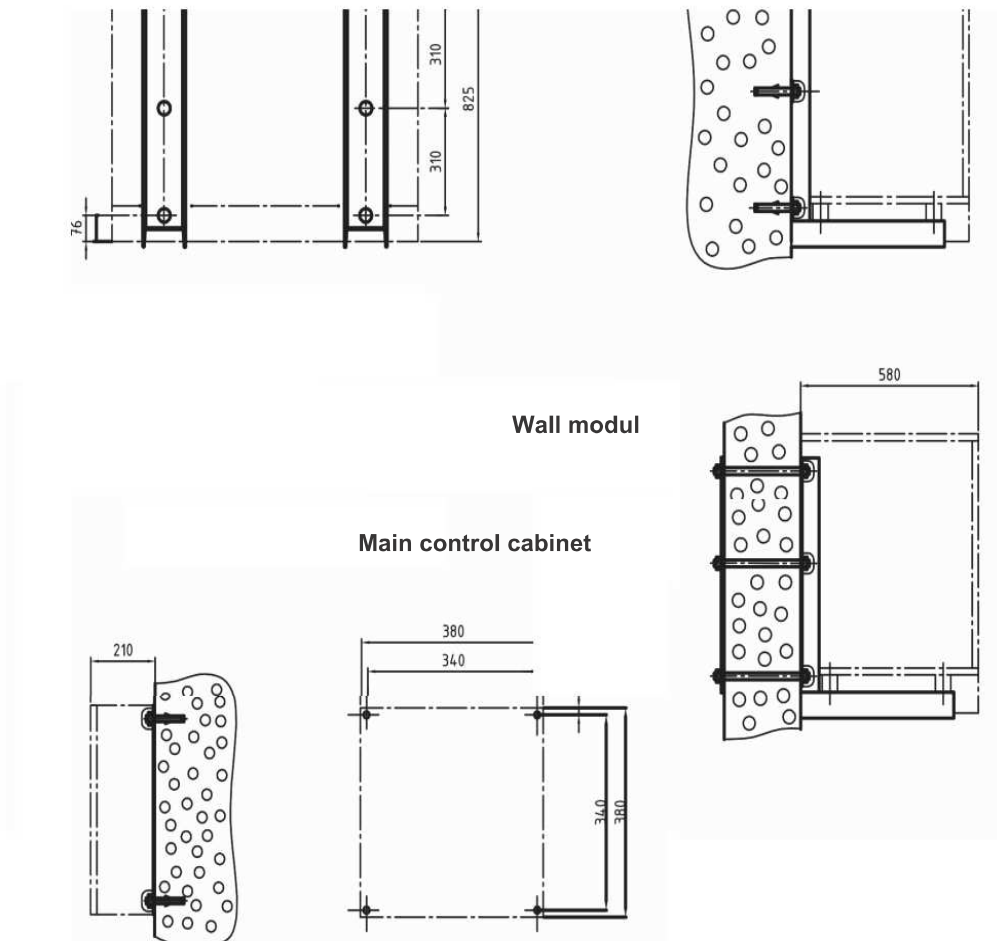

4.3 Connecting the machine

4.3.1 Electrical connection



The machine must be connected to the mains in accordance with the appropriate regulations by a locally authorized senior electrician. The electrical connection must comply with the current IEC regulations. 16 A slow-blow fuse must be installed in the building.

It is recommended to equip the machine with a faulty current monitor which interrupts the current connection in the event of the leakage current exceeds 30mA for 30 ms.

4.3.2 Water connection

The machine is to be connected to a tap of the pressure water pipe with of a hose suitable for pipe pressure

Required nominal widths and connection fittings:

Machine type	Nominal width	Hose fitting suitable for water Supply connection of the machine
FOM 918	½" DN 12	Hose coupling nipple with hose coupling nut ¾" and hose clamp
FOM 1024	¾" DN 20	
FOM 1415	¾" DN 20	

With a flow pressure of minimum 2 bar up to maximum 10 bar the water supply must be guaranteed according to the maximum volume flow of the corresponding machine type.

For the connection to a service water pressure pipe an expert must check whether the water quality corresponds to the requirements. The water supply is to be led via a fine filter, mesh size 200 µm.

4.3.3 Fuel oil connection

For the suction operation of the burner fuel pump a fuel storage tank has to be erected in accordance with the regulations. The fuel oil suction pipe and the return pipe have to be moved directly into the tank and connected to to the tank by means of pipe extensions.

The tank has to be erected in such a manner that the fuel oil is prevented from being contaminated.

In case a suction height of more than 2 m and/or a length of the suction pipe of more than 15 m are required, the burner must be connected to a fuel oil supply plant. For the installation of such a plant, the special guidelines for the FRANK fuel oil supply plants have to be kept to.

The oil atomizing burner can be connected to a double-strand system with forward and return run of the fuel oil supply plant.

The fuel oil connection has to be carried out by an expert.

4.3.4 Exhaust gas flow



For the exhaust gas flow – joint pipes, chimney – special regulations must be followed, e.g. DIN 4705 and DIN 18160.

The criteria are:

- Cross section
- Air funnel requirements
- Temperature process, dew point
- Material, surface protection
- Static strength, wall thickness

In general the exhaust gas conduct has to be agreed with the competent senior chimney sweeper, especially the connection to a chimney already existing. According to the regulations the machine must be connected to its own chimney.

For the connection of the machine to the chimney steel connection according to DIN 18160, part 2 resp. DIN 1298 must be used.

For the direct connection of the machine stub pipe to the connection pieces, the joint pipe offered by FRANK must be used.

4.3.5 Long-distance piping

The long-distance piping is to be carried out by a skilled fitter for oil and water systems. Only components of the FRANK long-distance piping range are to be used as the thermal and chemical constancy can be guaranteed for these parts only.



For the installation and maintenance of the long-distance piping special instructions have to be followed.

4.3.6 High-pressure hose and spraying device



Only components which are approved by the manufacturer and marked in accordance with regulations are to be used. High-pressure hose and spraying device are to be connected pressure-sealed to the machine. The high-pressure hose must not be driven over, pulled excessively or twisted.

4.3.7 Condensation water piping, Overflow

The customer must provide a drainage system for the condensation water penetrating from the water heater as well as for the water draining off from the overflow connection of the water inlet tank in a case of emergency.

5. Operation

5.1 Fuel

Fuel oil EL DIN 51603

Heating value $H_u = 11,86 \text{ kWh/kg}$ (10.200 kcal/kg)

5.2 Cleaning and preserving agents



Only the following FRANK cleaning and preservation agents and possibly certain other additional agents authorized by the manufacturer may be used, since material compatibility can be guaranteed for the agents only

FRANK--Cleaning and preserving agents

FRANKOCLEAN NER 0800

FRANKOCLEAN FZG 1170



The instructions for application of the cleaning and preserving agents must be observed. If necessary, wear protective glasses and safety clothing

5.2.1 Power supply to the control electronics in the spray gun

Two E-Block 9 V batteries supply the control electronics with electrical current. The battery life is approx. 200 operating hours.

A flashing light on the spray gun signals that the limit value of the battery voltage has been reached and that a battery change is necessary.

5.2.2 Receiver

The receiver is located in the main control cabinet, which controls the signals transmitted by the spray gun and triggers the switching operations of the machine control.

This involves switching the machine ON and OFF, delaying the switching on of the oil burner, switching the oil burner on and off as a function of the program, and switching the additive detergent on and off as a function of the program.

Seconds - when the spray gun is closed and prevents the machine from being switched ON / OFF frequently when the spray gun is opened / closed.

The switch-off delay is set to 10 seconds at the factory.

.

6. Operating instructions

6.1 Nozzles and recoil

The approved nozzle is adapted to the maximum flow rate, the admissible pump pressure and to the direct connection of a high-pressure hose pipe DN 8 x 10 m. The appropriate nozzle size is to be taken from the table below.

For long-distance pipings and/or longer hose pipes larger nozzles are to be used. The nozzle size is to be chosen and laid down in such a manner that the working pressure of the high-pressure stage (HD), indicated in section 2, is not exceeded.



When using the safety spray lance, the recoil should be taken into account, and the fact that torque is produced by the recoil when angled spray lances are in operation. This torque increases with the length of the lance

Admissible nozzles, code number	Jet shape	Spray angle	Flow rate l/min	Pump pressure bar	Recoil N
FOM 918					
00045	full jet	-	14,5	180	32
15045	flat jet	15 °			
25045	flat jet	25 °			
40045	flat jet	40 °			
50045	flat jet	50 °			
65045	flat jet	65 °			
FOM 1024					
00045	full jet	-	17	240	50
15045	flat jet	15 °			
25045*	flat jet	25 °			
40045	flat jet	40 °			
50045	flat jet	50 °			
65045	flat jet	65 °			
FOM 1415					
0008	full jet	-	23,0	150	54
1508	flat jet	15 °			
2508*	flat jet	25 °			
4008	flat jet	40 °			
5008	flat jet	50 °			
6508	flat jet	65 °			

* Provided nozzle is suitable for direct connection to a high-pressure connection DN 8 x 10 m without long-distance piping.

6.2 Operating pressures and spray flow rates

Infinite pressure/flow rate regulation

Set the desired operating stage on the handwheel of the overflow safety valve only when the machine is switched off and depressurized.

Hot water high-pressure stage (HD stage)	-	Turn handwheel to the rechts drehen right until the limit is reached
Steam stage (D stage)	-	Turn handwheel to the left until the limit is reached.

Type	Operating stage	Spray pressure bar	Spray volume l/min.
FOM 918	HD	108	14,5
	D	30	7,5
FOM 1024	HD	240	17,0
	D	30	9,0
FOM 1415	HD	150	23,0
	D	30	10,0

6.3 Operating temperatures

The operating temperature can be adjusted infinitely on the thermostat. There will be temperature fluctuations due to the switching difference of the thermostat and the characteristic feature of the water heater.

When working with high-pressure stage HD, the thermostat must be set below 100° C only. When working with steam stage D, the thermostat must be set to 150° C.

When the machine is operated with cold water, the thermostat must be set back until the limit is reached.

6.4 Operating the safety spray lance

Direct high-pressure safety spray lance at the object to be cleaned. Release and actuate safety lever on the spray gun. The water is now conveyed to the nozzle. Spray pressure builds up and quickly attains the selected operating pressure. Avoid an opening and closing of the spray gun in quick succession.



Do not direct high-pressure jet at persons, live parts or machine. The high-pressure hose has to be handled carefully in order to prevent to be driven over or to be pulled excessively. Buckling of the hose should be avoided.

6.5 Spraying with cleaning agents/Preserving agents

Set dosing valve to the desired dosing position. Final concentration of the cleaning and preserving agent in the water jet according to the following table:

Formulation concentration 1 : 10 (1 part cleaning agent, 10 parts water)

Percentage of final concentration of cleaning agent in the water jet

Dosing valve position	High pressure stage HD		
	FOM 918	FOM 1024	FOM 1415
1	0,21	-	-
2	0,34	0,04	0,10
3	0,38	0,10	0,16
4	0,42	0,17	0,21
5	0,46	0,20	0,26
6	0,50	0,25	0,27
7	0,53	0,30	0,31
8	0,54	0,33	0,34
9	0,56	0,35	0,38
10			
	Steam stage D		
1	0	-	-
2	0,43	-	-
3	0,58	0,13	0,17
4	0,66	0,26	0,24
5	0,70	0,35	0,37
6	0,76	0,42	0,44
7	0,81	0,56	0,55
8	0,86	0,65	0,58
9	0,91	0,76	0,65
10	0,93	0,86	0,79

If higher concentrations are required, the formulation of the cleaning agent has to be increased. The maximum suction height for the cleaning agent is 1 m. The suction baskets must be located below the cleaning agent level in the tank. The desired cleaning agent A or B can be selected on the button of the control box at the washing bay.

ATTENTION!

When the cleaning agent tank is empty, shut the corresponding dosing valve. Do not select the programme with the empty tank, as air will be sucked which can damage the pump.

6.6 Starting the machine

Set ON/OFF switch to position "1". Machine is ready for operation.

6.7 Operation of the safety spray lance



Securely hold the safety spray lance with both hands. Avoid opening and releasing the spray gun in rapid succession.

Select program by actuating the rotary selector on the spray gun.

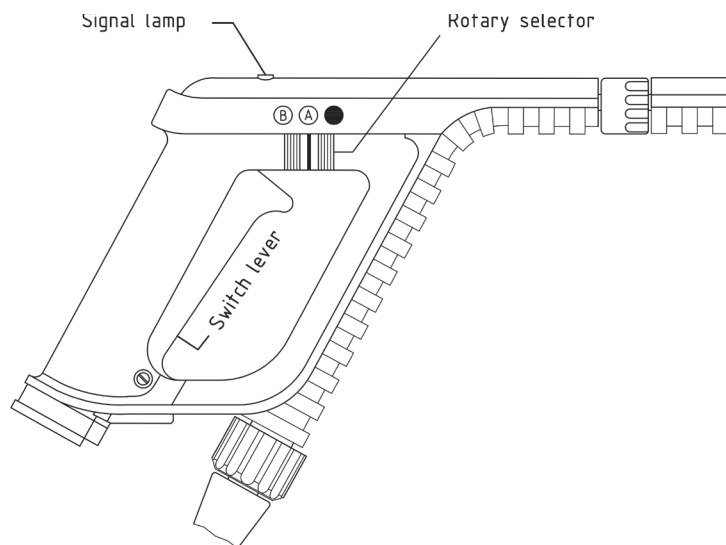

Program "COLD"



(blue symbol)

Operation with cold water without cleaning agent

Program "HOT"



(red symbol)

Operation with hot water without cleaning agent

Program "HOT WITH DETERGENT"



(red symbol)

Operation with hot water using detergents

Direct spray appliance at the object to be cleaned.

Actuate safety control lever. The pressure builds up and quickly attains the selected operating pressure level.



7. Default setting

In our works the machine has been set and tested for the values specified under "2 Technical data". The initial settings and tests in our works were performed under the following conditions:

Room temperature (air temperature):	18° C
Mean atmospheric pressure:	986 m
Fuel oil:	EL DIN 51603
Calorific value:	11,86 kWh/kg (10.200 kcal/kg)

8. Operation

8.1 Preparations for Commissioning

Compare the technical data of the type plate to the technical data of this operation manual. Check level of the high-pressure pump. Connect high-pressure pipe (s), high pressure hose pipe (s), Spray lances with spray gun(s) so that they are sealed against pressure.

8.2 Commissioning

8.2.1 Initial commissioning

Open isolating valve of the water supply and fill water inlet tank with water. Open isolating valve of the oil supply pipe. Loosen high-pressure connection on the machine.

Set thermostat to 95 °C.

Starting the machine.

Set main and emergency switch which is in the control cabinet to „1“. Start the machine by actuating the START button located on the control box at the washing bay. Operate and deaerate the machine without the oil burner running and without the adding of cleaning agents for about 1 minute, at zero pressure. Reconnect high-pressure pipe(s), high-pressure hose pipe(s), spray lances with spray gun(s) in that manner that they are sealed against pressure.

Check Oil atomizing burner:

Set main and emergency switch to „1“. Start the machine by actuating the START button located on the control box at the washing bay. Switch on the oil atomizing burner by actuating the programme button „HOT“ which is located on the control box at the washing bay. Check operating temperatures of the machine. If the required value of the operating temperature cannot be attained, have it corrected by an expert.

Check exhaust gas values by means of a smoke gas analyser. The measuring values have to be recorded in a check list. Warranty claims can only be accepted when the check list has been filled in completely.

8.2.2 Starting and operation

Set main and emergency switch in main switch cabinet to 1!
 Select operating pressure and spray volume, see item 6.2.
 Set operating temperature on the thermostat, see item 6.3.
 Set dosage of cleaning and preservation/agent, see item 6.5.
 Start machine by actuating the START button located on the control box at the washing bay.

ATTENTION!

Machine starts with spray gun closed and switches off again immediately.
 Select cleaning programme by pressing the START button on the control cabinet of the washing bay, see item 6.6 operating the safety spray lance, see item 6.4.

8.3 Battery change

After approx. 200 operating hours the signal lamp indicates that a battery change is necessary.

The batteries required: 2 pieces E-block 9 V.

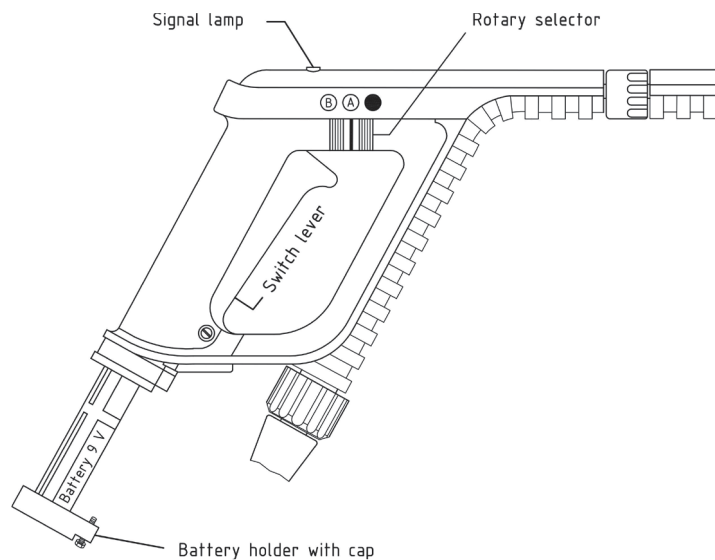

Loosen the screw of the battery cap beneath the pistol grip and pull out cap with battery holder and battery.

Remove used up batteries.

Insert new batteries with the plus pole showing to the inner side according to the mark + on the battery holder. Put battery holder back into the gun grip and press the cap over the gasket until it bottoms.

Drive screw in.

8.4 Operating the safety spray lance

Direct high-pressure safety spray lance at the object to be cleaned. Actuate the lever on the spray gun. The water is now conveyed to the nozzle. Spray pressure builds up and quickly attains the selected operating pressure. Avoid an opening and closing of the spray gun in quick succession.



Do not direct high-pressure jet at persons, live parts or machine. The high-pressure hose has to be handled carefully in order to prevent to be driven over or to be pulled excessively. Buckling of the hose should be avoided.

9. Taking the machine out of order

Keep the machine running for at least 1 minute with cold water but without the addition of cleaning agents to flush out all chemical residues.

Release safety lever of the spray gun, close spray gun. The machine is switched off by means of a pressure switch.

The time sequence of the automatic cutoff system starts. The machine remains in operating condition until the period sequence has finished.

The machine can only be restarted by pressing the START button again.



For longer periods of non-use and/or maintenance and servicing purposes, set main and emergency switch to „0“. Open gun until machine is depressurized. Secure safety lever of the spray gun using the locking device to prevent any unintentional opening of the spray gun. Turn off water supply. In case of danger – e.g. leakage on spray appliance or on high-pressure hose pipe –press STOP button on the control cabinet at the washing bay.

10. Restarting of the machine

When restarting the machine, make sure the machine and particularly the power supply cord, the high-pressure hose and the safety spray lance are in perfectly good condition.

11. Maintenance



Maintenance and repair works may only be done by qualified personnel. Set main and emergency switch to „0“ and protect against switching on. Keep off hot parts – danger of burning. Maintenance and repair works may only be carried out by qualified staff.

11.1 High pressure pump

Change the pump lubrication oil at intervals of approx. 200 operating hours, but at the latest, after 3 months of operation. For lubrication use branded oils of SAE 90 quality only. When changing the oil, remove the draining screw, drain the oil and dispose it properly. Then put the oil draining screw back into place and refill new oil through the funnel until the upper mark on the dipstick is reached. Between oil changes check the oil level regularly; the oil level.

11.2 Deliming

If no soft or softened water is used, lime deposits will settle down in the heating coil. Depending on the local water hardness, the heating coil must be delimed in regular intervals to protect the unit from damages. Do not wait until the pressure is too high and the safety valve responds or the protective motor switch cuts off the machine.

Deliming is carried out as follows.

Set motor switch to position „0“. Loosen elbow joint of the suction hose on the water inlet tank and connect to deliming hose (which is a 1/2" hose featuring a filter basket at one end and straight hose sleeve with 3/4" external thread at the other end) and direct out-side.

Turn the knob of the dosing valve to position „0“. Fully close the thermostat hand-wheel.

Fill 16 litres of hot water into a tank and add 2 litres of deliming compound SP.



Caution! The deliming agent is corrosive. Wear safety clothing. In case of skin contact, rinse with water immediately.

Insert deliming hose into the tank, unscrew spray nozzle from the spray lance and place lance into the tank. The deliming hose filter must always be situated below the liquid level within the tank. Turn on the machine. The deliming process is completed when the liquid has stopped foaming. Turn off the machine.

Empty tank, properly dispose of the deliming liquid. Fill 16 litres clear, cold water into the tank and add 0,5 litres alkaline cleaning agent. Reinsert deliming hose and spray lance into the tank.

Turn on the machine and flush heating coil using the alkaline solution for 5 minutes. Turn off the machine, set motor switch to position „0“. Reconnect suction hose to the water inlet tank, clean and reassemble spray nozzle. Mount and lock hood.

11.3 Cleaning the heating coil

In our works the burner has been adjusted in that way that with normal operation a contamination of the heating coil is not probable. However, under special circumstances a contamination is possible. Therefore a regular check of the heating coil condition is required every 6 months. For cleaning purposes remove hood, remove burner from mounting plate and close burner flame tube. Remove rear heating coil cover after loosening the 3 fastening screws.

In case of serious contamination the heating coil must be cleaned in accordance with the „Instructions for cleaning the heating coil of the leated wall module no. 2-08.62.10.000“.



For mounting the rear heating coil cover the following must be paid attention to: the ceramic sealing cord of the heating coil cover must be replaced using the proper quality and dimensions. Check the chamotte plate for breakage or fissures and replace it, if necessary.

Replace isolating disk if damaged. Seal opening between chamotte plate and guiding ring with bag in the area of the „bag“ by means of the ceramic sealing cord. Securely tighten the 3 fastening screws on the heating coil cover, but do not use too much force to prevent the heating coil cover from deforming. Mount high-pressure pipes and associated joints, particularly the brass connectors on the entering and exiting side of the heating coil cover from deforming. Mount high-pressure pipes and associated joints, particularly the brass connectors on the entering and exiting side of the heating coil, so that they are sealed against pressure.

12. Troubles, causes and troubleshooting

Trouble	Possible cause	What to do about it
Machine does not run or switches off during operation.	Batteries in the spray gun used up	Replace batteries Type E - 9 V block (See 23.)
	Interruption of the control line between the receiver and the insulating piece on the high-pressure hose connection of the wall module	Have the cable connections set up properly by a specialist
	Metallic connection "short circuit" between machine ground and high pressure - hose - connection of the machine	Remove metallic connection; If necessary, have the insulating piece replaced by a specialist.
	Wrong high pressure hose inserted	Use the correct high pressure hose; electrical resistance between the two metallic hose ends may not exceed 1 ohm.
	High pressure hose longer than 20m, lies on heavily soiled floor, signal weakened	Insert gray high pressure hose with better insulating hose jacket.
	For a stationary system e.g. wall module FOM not correctly installed signal control line	Special installation instructions request the manufacturer's writings and have the installation carried out by qualified personnel.
	Control electronics of the spray gun (transmitter) defective.	Have the spray gun replaced by a specialist

Trouble	Possible cause	What to do about it
Machine does not run or switches off during operation.	<p>Torn solder is broken on the spray gun battery holder</p> <p>Corrosion on the battery holder inside the battery housing due to leaks in the battery cap of the spray gun</p> <p>Receiver defective</p>	<p>Have the soldered point repaired by a specialist, soft solder</p> <p>Replace the battery holder by an expert, seal the battery cap in accordance with regulations, have the O - ring for the battery seal replaced if necessary</p> <p>Have the receiver replaced by an electrician</p>
No additive flow in the TCC version	<p>Spray gun control electronics defective</p> <p>Program - malfunctions, switching bolt function</p> <p>Receiver defective</p>	<p>Replace spray gun by an expert</p> <p>See "Program - disorders "</p> <p>Have the receiver replaced by an electrician</p>
Burner does not work	<p>TCC version receiver defective.</p> <p>Control electronics of the spray gun defective in the TCC version</p> <p>Blown fuse on the receiver board for the burner circuit</p> <p>Solder connection of the fuse holder on the receiver board torn</p>	<p>Have the receiver replaced by an electrician.</p> <p>Have the spray gun replaced by a specialist.</p> <p>Have the cause clarified and eliminated by an electrician, have the fuse replaced.</p> <p>Have an electrician replace the fuse holder and have it soldered in accordance with the regulations.</p>
Program disturbances; the program setting on the spray gun is not followed by the selected program	The switch latch in the spray gun does not operate the transmitter's microswitches as required; the pretension of the switch bolt is too far from the microswitches.	Have the switch latch set correctly by a specialist, tighten the screw in the switch latch until both transmitter microswitches are alternately correctly confirmed.

13. Checking

The machine is in accordance with the accident prevention regulation "Working with liquid jets" (VBG87) if necessary, but at least every 12 months, to be checked by a specialist as to whether safe operation is largely guaranteed.

The special safety check of the spray gun is to be carried out as follows:

Disconnect the spray lance from the spray gun. To do this, loosen the jet pipe screw connection. Remove the switching lever with the spring mechanism of the spray gun.

The machine must be ready for operation. Set the ON / OFF switch to 1.

Grip the pistol grip with one hand and use the other hand to actuate the plunger of the two built-in switches one after the other using a thin rod.

The machine must not start up.

Check whether the machine starts up correctly when both plungers are actuated at the same time.

Should the machine start up improperly when only one switching plunger is actuated

The spray gun must be replaced immediately.

The results of the tests must be recorded in writing.

Furthermore, an oil or gas-heated machine must be checked annually by the responsible district chimney sweep for compliance with the required ejection limit values due to the "First Ordinance for Implementing the Federal Immission Control Act".

14. Prevention of accidents

The machine has been designed as to exclude accidents if operated properly.



The operators must be warned of the danger of injury by hot machine parts and by the high-pressure jet.

The regulations „Working with liquid spray appliances“ (VBG 87) must be followed.

The operation manual has to be handed over to the operating personnel in order to ensure a fail-safe and working-safe operation.

15. Safety instructions

For reasons of safety only those spare parts and accessories which are approved by the manufacturer and specified in the appropriate spare parts list are to be used. The manufacturer is responsible for the effects on the safety, reliability and performance of the machine only when the following conditions are fulfilled

- servicing, extensions, adjustments, modifications and repair works are carried out by persons authorized by the manufacturer and recorded
- connection to the electric power supply is carried out in accordance with national regulations considering the local operational area.
- machine is used in accordance with the Operating Instructions

For the installation and operation of this oil firing plant a report, permission and possibly authorization is required. The fuel oil installation must correspond to the DIN regulations 4656 ad 4788. The accessories and all fittings must be allowed by DVGW. Furthermore the regulations and guidelines of other countries, Lands of the Federal Republic of Germany, towns, districts and local supply utilities must be followed.



Instructions for cleaning the heating coil of the heated wall module FOM/FGM Artikel-Nr. 2-08.62.10.000

Sufficient space must be provided for demounting the heating coil: Minimum 1 m free space on the right side of the heating coil.

The cleaning of the heating coil must be prepared and carried out as follows:

- Minimum 1 m free space on the right side of the heating coil.
- Remove the right casing door together with the right casing side panel by loosening the 2 screws on the right casing side panel and 1 screw on the casing cover
- Unscrew the support angle for the casing cover on the heating coil cover of the water heater.
- Remove heating coil cover of the water heater together with the insulating plate and chamotte baffle plate by loosening the 3 fixing nuts.
- Loosen the high-pressure pipe leading to the heating coil inlet on both sides.
- Loosen the high-pressure pipe on the heating coil outlet.
- Remove thermostat probe.
- Unscrew brass connection pieces on the inlet and outlet of the heating coil.
- Pull out heating coil and guide ring with bag, remove guide ring from heating coil.
- Tightly connect the high-pressure pipe directly behind the flow monitor switch to the open high-pressure pipe on the heating coil outlet by means of a VS hose connection, heating coil bypass no. 2-08.54.70.000 in that way that they are sealed against pressure.
- Clean heating coil with the high-pressure jet. Thoroughly clean coiled tubing and opening on the inside and outside. Properly drain resp. collect and dispose dirt water.
- Dry-clean water heating coating on the inside. Remove dirt particles by sweeping or brushing.
- Reassemble the removed parts. The ceramic sealing cord of the heating coil cover must be replaced using the proper quality and dimensions. Check the chamotte plate for breakage or fissures and replace it, if necessary. Seal opening between chamotte plate and guide ring with bag in the area of the „bag“ by means of the ceramic sealing cord. Securely tighten the 3 fastening screws on the heating coil cover, but do not use too much force to prevent the heating coil cover from deforming.
- Mount high-pressure pipes and associated joints, particularly the brass connectors on the entering and exiting side of the heating coil, so that they are sealed against pressure.



EC Declaration of Conformity



We declare that the construction of the machine which is subject of this declaration, is in conformity with the following directives and standards:

Machinery Directives	98/37/EG
Low Voltage Directives	2006/95/EG
EMC Directive	2004/108/EG

EN 292
EN 61000 - 6 - 3 : 2001 + A11 : 2004
EN 61000 - 6 - 2 : 2005
IEC 335 - 2

Machine type FOM 918 TCC
 FOM 1024 TCC
 FOM 1415 TCC

Frank Hochdruck- & Dampftechnologie GmbH
Bochumer Straße 15
D-57234 Wilnsdorf

.....
Samir El-Assal, Managing Director

*Aktualisiert durch den TÜV Hessen
Frankfurt am Main, Juli 2007





AB0284

FRANK GmbH
Hochdruckreiniger

Bochumer Str. 15
57234 Wilnsdorf

Fon +49(0)2739 / 47993 - 0

www.frank-hdr.de
info@frank-hdr.de

